



milkshake mixers

MODELS: WMSB01, WMSB01V, WMSB02, WMSB02V, WMSW01, WMSW01V

APPLICATIONS

- Mixing of milkshake, thickshakes and other comparable products

STANDARD FEATURES

- Full metal body construction
- Cup operated auto-switch operation and on/off button
- Adjustable cup rest to support multiple cup sizes and unattended operation
- Powerful 15,000 rpm motor
- Metal spindles include special thickshake blade
- Reliable and durable.

OPTIONS

- Full variable speed control (V models) for maximum controllability
- Single, twin and wall-mounted designs available

SPECIFICATIONS

WMSB01 & WMSB01V: Kw .12 Amps .5

Width: 178 Depth: 190 Height: 473

WMSB02 & WMSB02V: Kw .24 Amps 1

Width: 300 Depth: 190 Height: 473

WMSW01 & WMSW01V: Kw .12 Amps .5

Width: 97 Depth: 160 Height: 400

Dealer:



Model WMSB02V shown

Power Supply located on back right hand side of each benchtop unit

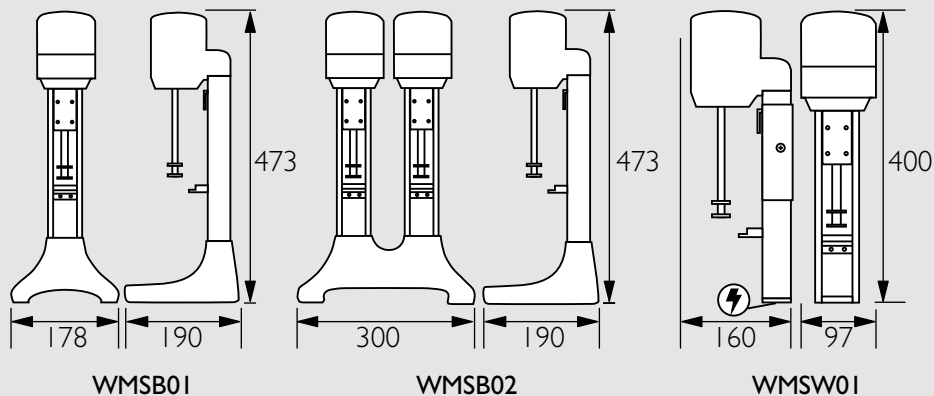

We reserve the right to alter specifications of products without notice

For details of your local dealer contact:

QLD, NT, WA, International
ph 07 3344 2444 fax 07 3345 6403
email fse@stoddart.com.au

NSW, ACT
ph 02 9817 7700 fax 02 9817 7800
email gladesville@stoddart.com.au

VIC, SA, TAS
ph 03 9543 9922 fax 03 9543 9944
email melbourne@stoddart.com.au

Manufactured by: Tom Stoddart Pty Ltd, 215 Jackson Road Sunnybank Hills, Qld 4109 Australia