

Electric Tilting Bratt/Braising Pans

The Elco 700HP range is comprised of over 100 models designed to guarantee the highest level of performance, reliability, energy saving, safety standards and ergonomic operation. These concepts are reflected in the total modularity of the range that ensures numerous configurations, either free-standing or bridged. Elco 700HP demonstrates how advanced technology can satisfy the needs of the professional caterer. The models detailed on this sheet are Freestanding Electric Tilting Bratt/Braising Pans.



178700

EASY TO INSTALL

- Main connections can be accessed via the rear or base of the unit.

EASY TO CLEAN

- One piece pressed worktop in 1,5mm stainless steel with smooth, rounded corners.
- Front panel in stainless steel with Scotch Brite finish.
- All models have right-angled, laser cut side edges to allow flush-fitting joints between units eliminating gaps and possible dirt traps.

EASY TO USE

- Working temperature (from 120°C to 280°C) controlled through a thermostat.
- Well and double skinned lid/worktop in stainless steel. Front panels in stainless steel with Scotch Brite finish.
- Choice of well cooking surface in mild steel or stainless steel (8mm).
- Manual tilting mechanism to facilitate the emptying of the Bratt Pan.

- Armoured elements in stainless steel mounted under the external base of the well.
- Safety thermostat.
- Feet in stainless steel adjustable in height 50mm.

EASY TO MAINTAIN

- Ease of maintenance guaranteed by frontal access to all working components.
- IPX4 water protection.

EASY ON THE ENVIRONMENT

- 98% recyclable by weight.
- CFC free packaging.



Electrolux

Elco 700HP
Electric Tilting Bratt/Braising Pans

CGNB010

2008-12-20

TECHNICAL DATA	QBRE801 178700	QBRE800 178701
Power supply	Electric	Electric
External dimensions - mm		
width	800	800
depth	730	730
height	850	850
height adjustment	50	50
Usable well dimensions - mm		
width	720	720
depth	450	450
height	200	200
Cooking surface		
material	mild steel	stainless steel
Well capacity - min/max - lt.	56	56
Cooking surface dimensions - mm		
width	680	680
depth	410	410
Working temperature - min/max - °C	120, 280	120, 280
Power - kW		
installed-electric	11	11
Net weight - kg.	105	105
Supply voltage	400 V, 3N, 50/60	400 V, 3N, 50/60

Subject to change without notice

Elco 700HP
Electric Tilting Bratt/Braising Pans

CGNB010

2008-12-20

	QBRE801 178700	QBRE800 178701
ACCESSORIES		
2 SIDE KICKING STRIPS-CONCRETE INSTALL. 4 FEET FOR CONCRETE INSTALLATION	206265	206265
FLANGED FEET KIT	206136	206136
FRONT.KICK.STRIP F.CONCRETE INST.1000 MM	206150	206150
FRONT.KICK.STRIP F.CONCRETE INST.1200 MM	206151	206151
FRONT.KICK.STRIP F.CONCRETE INST.1600 MM	206152	206152
FRONT.KICK.STRIP F.CONCRETE INST.200 MM	206146	206146
FRONT.KICK.STRIP F.CONCRETE INST.400 MM	206147	206147
FRONT.KICK.STRIP F.CONCRETE INST.800 MM	206148	206148
FRONTAL HANDRAIL 1200 MM	216049	216049
FRONTAL HANDRAIL 1600 MM	216050	216050
FRONTAL HANDRAIL 400 MM	216046	216046
FRONTAL HANDRAIL 800 MM	216047	216047
FRONTAL KICKING STRIP 1000 MM	206177	206177
FRONTAL KICKING STRIP 1200 MM	206178	206178
FRONTAL KICKING STRIP 1600 MM	206179	206179
FRONTAL KICKING STRIP 200 MM	206174	206174
FRONTAL KICKING STRIP 400 MM	206175	206175
FRONTAL KICKING STRIP 800 MM	206176	206176
LARGE HANDRAIL(PORTIONING SHELF)400 MM	216185	216185
LARGE HANDRAIL(PORTIONING SHELF)800 MM	216186	216186
PAIR OF SIDE KICKING STRIPS	206249	206249

Subject to change without notice

Elco 700HP
Electric Tilting Bratt/Braising Pans

178700, 178701

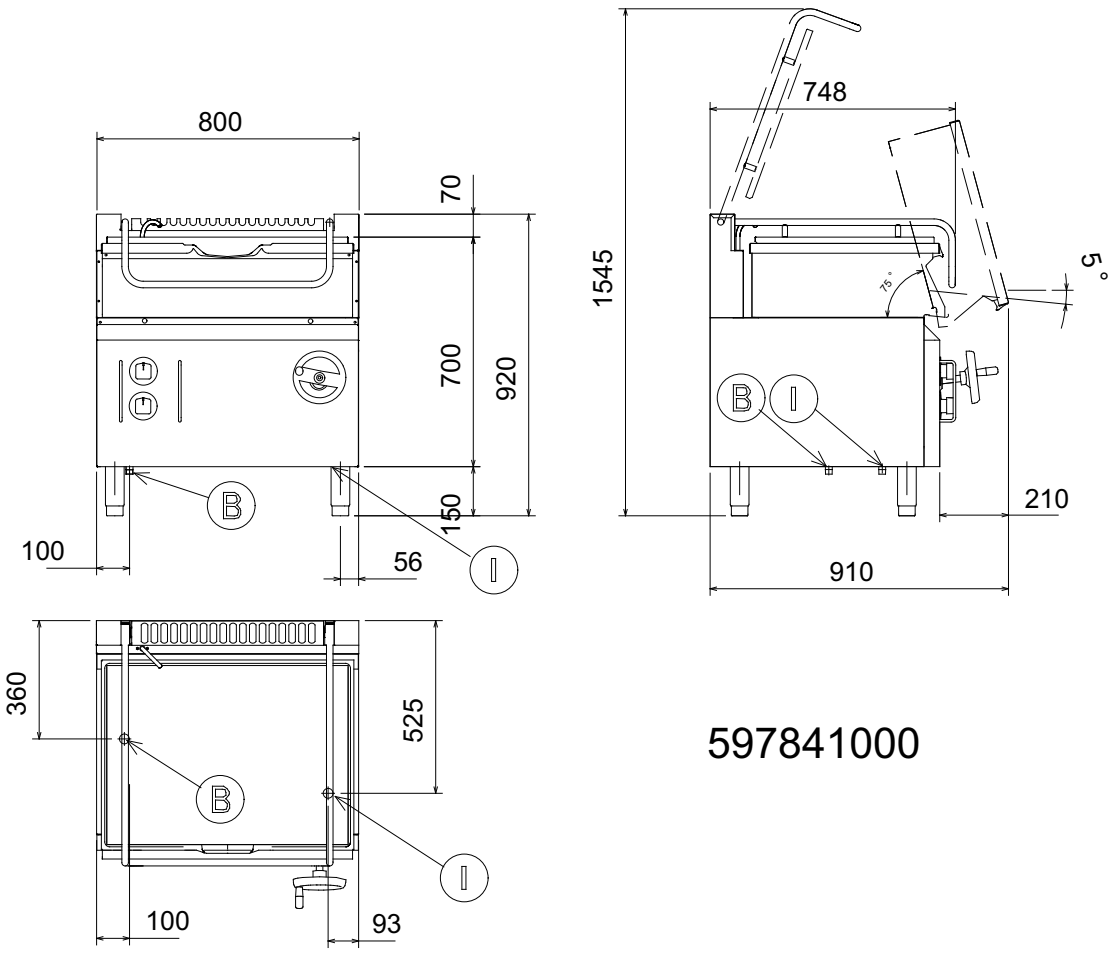

597841000

LEGEND	QBRE801 178700	QBRE800 178701
	B - Cold water inlet	1/2"
I - Electrical connection	400 V, 3N, 50/60	400 V, 3N, 50/60

CGNB010

2008-12-20

Subject to change without notice