

Freestanding Electric Fryers

The Elco 700HP range is comprised of over 100 models designed to guarantee the highest level of performance, reliability, energy saving, safety standards and ergonomic operation. These concepts are reflected in the total modularity of the range that ensures numerous configurations, either free-standing or bridged. Elco 700HP demonstrates how advanced technology can satisfy the needs of the professional caterer. The models detailed on this sheet are Freestanding Electric Fryers.



178721

EASY TO INSTALL

- All top models are provided with a service duct to facilitate installation and can be mounted on open base cupboards or bridging supports.
- Main connections can be accessed via the rear or base of the unit.

EASY TO CLEAN

- One piece pressed worktop in 1,5mm stainless steel with smooth, rounded corners.
- Front panel in stainless steel with Scotch Brite finish.
- All models have right-angled, laser cut side edges to allow flush-fitting joins between units eliminating gaps and possible dirt traps.

- Oil drainage via a tap.
- Recessed, double skinned door with pressed internal panel for air-tight closure and better hygiene.
- Inside door panel in stainless steel.
- Handles on the oven in stainless steel.
- Feet in stainless steel adjustable up to 50mm in height.

EASY TO USE

- Working temperature from 105°C to 185°C.
- Additional overheat safety thermostat.

- The "V" shaped wells have the burners attached to the outside allowing an increased life of the oil, greater productivity and an easier cleaning.
- Incoloy armoured high efficiency heating elements inside the well.

EASY TO MAINTAIN

- IPX4 water protection.

EASY ON THE ENVIRONMENT

- 98% recyclable by weight.
- CFC free packaging.



Electrolux

**Elco 700HP
Freestanding Electric Fryers**

CGED010

2008-12-23

	QFRE481 178720	QFRE831 178721	QFRE460 178724	QFRE810 178725	QFRE8102 178733	QFRE455 178726	QFRE805 178727
TECHNICAL DATA							
Power supply	Electric	Electric	Electric	Electric	Electric	Electric	Electric
External dimensions - mm							
width	400	800	400	800	800	400	800
depth	730	730	730	730	730	730	730
height	850	850	850	850	850	850	850
height adjustment	50	50	50	50	50	50	50
N° of wells	1	2	1	2	2	1	2
Usable well dimensions - mm							
width	240	240	240	240	240	240	240
depth	380	380	380	380	380	380	380
height	235	235	285	285	285	505	505
Thermostatic	●	●	●	●	●	●	●
Temperature limiter	●	●	●	●	●	●	●
Well capacity - min/max - lt.	5.5, 7	5.5, 7	12, 14	12, 14	12, 14	13, 15	13, 15
Power - kW							
installed-electric	5.4	10.8	8.7	17.4	17.4	10	20
Net weight - kg.	40	60	35	81	81	55	81
Supply voltage	400 V, 3N, 50/60	400 V, 3N, 50/60	400 V, 3N, 50/60	400 V, 3N, 50/60	230 V, 3, 50/60	400 V, 3N, 50/60	400 V, 3N, 50/60

Subject to change without notice

**Elco 700HP
Freestanding Electric Fryers**

	QFRE481 178720	QFRE831 178721	QFRE460 178724	QFRE810 178725	QFRE8102 178733	QFRE455 178726	QFRE805 178727
INCLUDED ACCESSORIES							
BASKET FOR 14/15 LT FRYERS			1	2	2	1	2
BASKET FOR 7 LT FRYERS	1	2					
LEFT SIDE DOOR FOR OPEN BASE CUPBOARD		1		1	1		1
RIGHT SIDE DOOR FOR OPEN BASE CUPBOARD	1	1	1	1	1	1	1
ACCESSORIES							
2 1/2 BASKETS FOR 14/15 LT FRYERS			921692	921692	921692	921692	921692
2 SIDE COVERING PANELS FOR TOP-D=700MM	216277	216277	216277	216277	216277	216277	216277
2 SIDE COVERING PANELS H=700 D=700	216000	216000	216000	216000	216000	216000	216000
2 SIDE KICKING STRIPS-CONCRETE INSTALL.	206265	206265	206265	206265	206265	206265	206265
4 FEET FOR CONCRETE INSTALLATION	206210	206210	206210	206210	206210	206210	206210
BASKET FOR 14/15 LT FRYERS			921691	921691	921691	921691	921691
BASKET FOR 7 LT FRYERS	921608	921608					
CHIMNEY COVER 400MM OPEN	206284		206284			206284	
CHIMNEY COVER 800MM OPEN-LARGE CHIMNEY		206273		206273	206273		206273
DEFLECTOR FOR FLOURED PRODUCTS-15L FRYER						921696	921696
FILTER FOR FRYER OIL COLLECTION BASIN	921693	921693	921693	921693	921693	921693	921693
FLANGED FEET KIT	206136	206136	206136	206136	206136	206136	206136
FRONT.KICK.STRIP F.CONCRETE INST.1000 MM	206150	206150	206150	206150	206150	206150	206150
FRONT.KICK.STRIP F.CONCRETE INST.1200 MM	206151	206151	206151	206151	206151	206151	206151
FRONT.KICK.STRIP F.CONCRETE INST.1600 MM	206152	206152	206152	206152	206152	206152	206152
FRONT.KICK.STRIP F.CONCRETE INST.200 MM	206146	206146	206146	206146	206146	206146	206146
FRONT.KICK.STRIP F.CONCRETE INST.400 MM	206147	206147	206147	206147	206147	206147	206147
FRONT.KICK.STRIP F.CONCRETE INST.800 MM	206148	206148	206148	206148	206148	206148	206148
FRONTAL HANDRAIL 1200 MM	216049	216049	216049	216049	216049	216049	216049
FRONTAL HANDRAIL 1600 MM	216050	216050	216050	216050	216050	216050	216050
FRONTAL HANDRAIL 400 MM	216046	216046	216046	216046	216046	216046	216046
FRONTAL HANDRAIL 800 MM	216047	216047	216047	216047	216047	216047	216047
FRONTAL KICKING STRIP 1000 MM	206177	206177	206177	206177	206177	206177	206177
FRONTAL KICKING STRIP 1200 MM	206178	206178	206178	206178	206178	206178	206178
FRONTAL KICKING STRIP 1600 MM	206179	206179	206179	206179	206179	206179	206179
FRONTAL KICKING STRIP 200 MM	206174	206174	206174	206174	206174	206174	206174
FRONTAL KICKING STRIP 400 MM	206175	206175	206175	206175	206175	206175	206175
FRONTAL KICKING STRIP 800 MM	206176	206176	206176	206176	206176	206176	206176
LARGE HANDRAIL(PORTIONING SHELF)400 MM	216185	216185	216185	216185	216185	216185	216185
LARGE HANDRAIL(PORTIONING SHELF)800 MM	216186	216186	216186	216186	216186	216186	216186
PAIR OF SIDE KICKING STRIPS	206249	206249	206249	206249	206249	206249	206249
RIGHT AND LEFT SIDE HANDRAILS	206240	206240	206240	206240	206240	206240	206240
SEDIMENT TRAY FOR 15L FRYER						206235	206235
UNCLOGGING ROD F.15LT FRYER DRAIN.PIPE						921695	921695

CGED010

2008-12-23

Subject to change without notice

Elco 700HP
Freestanding Electric Fryers

178720

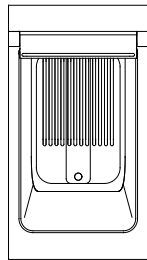
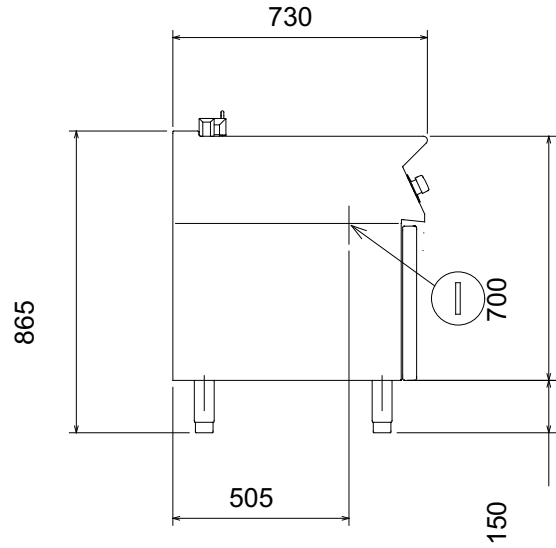
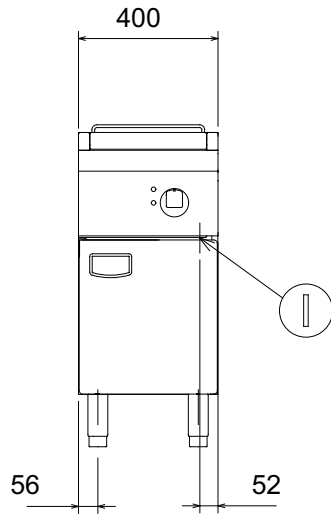

597841600

LEGEND

I - Electrical connection

QFRE481
178720

400 V, 3N, 50/60

CGED010

2008-12-23

Subject to change without notice

Elco 700HP
Freestanding Electric Fryers

178721

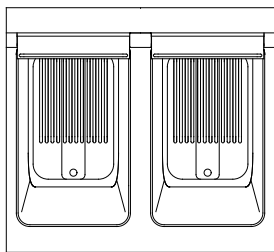
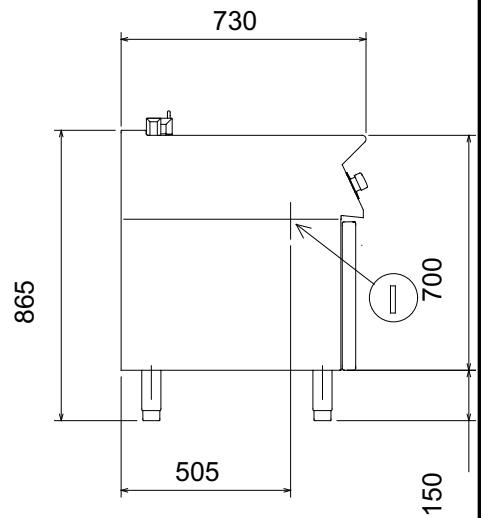
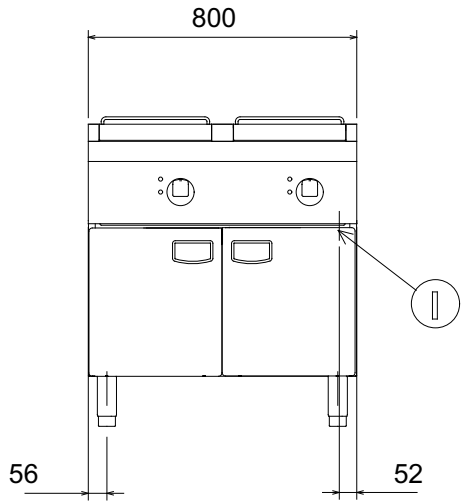

597841700

CGED010

2008-12-23

LEGEND

I - Electrical connection

QFRE831
178721

400 V, 3N, 50/60

Subject to change without notice

Elco 700HP
Freestanding Electric Fryers

178724

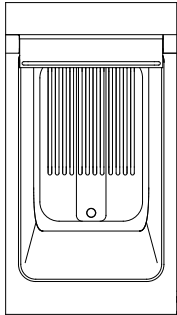
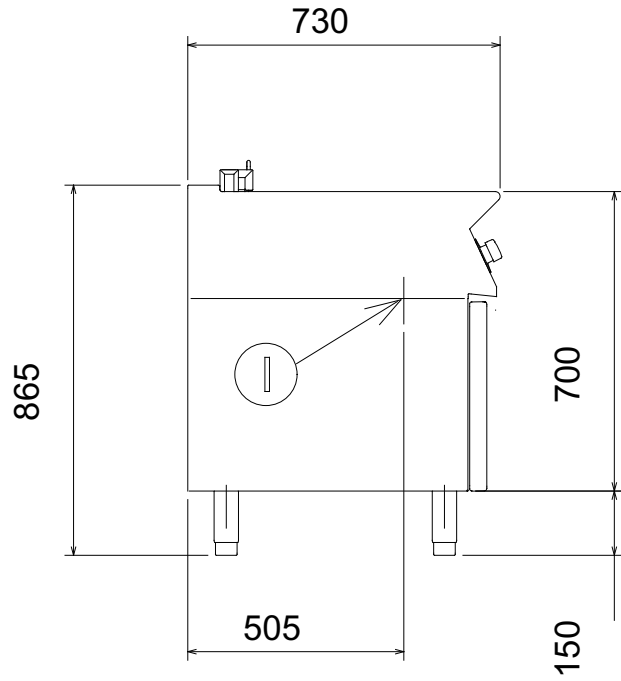
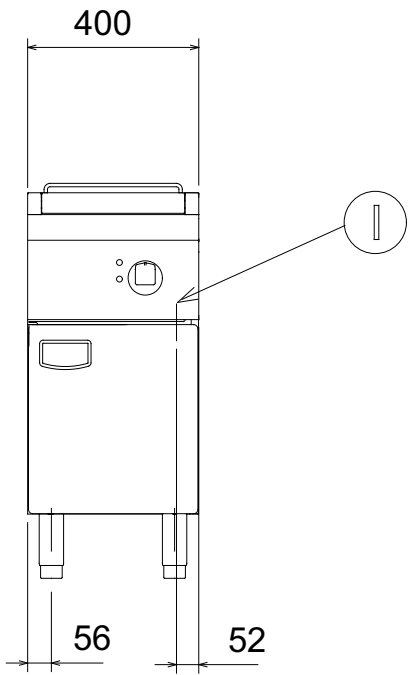

597842000

LEGEND

I - Electrical connection

QFRE460
178724

400 V, 3N, 50/60

CGED010

2008-12-23

Subject to change without notice

**Elco 700HP
Freestanding Electric Fryers**

178725, 178733

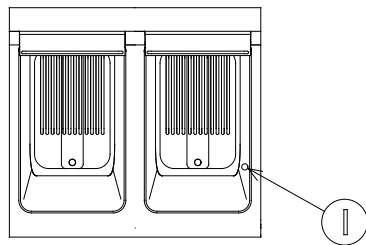
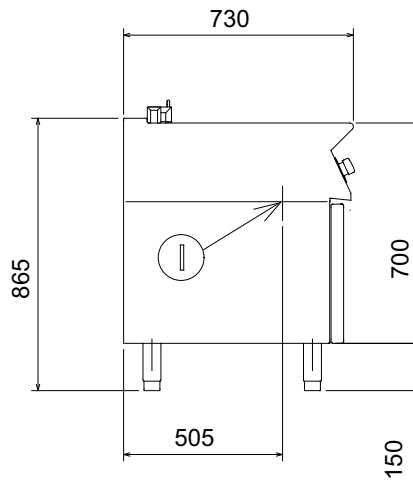
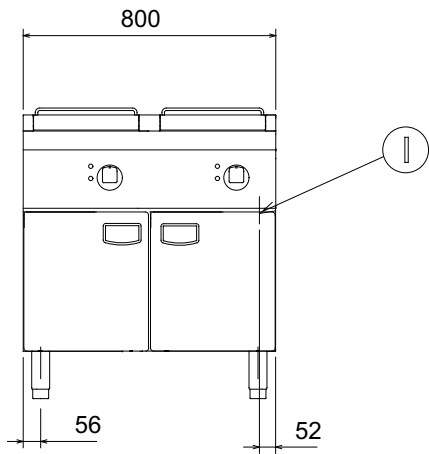

597842100

CGED010

2008-12-23

Subject to change without notice

LEGEND	QFRE810 178725	QFRE8102 178733
	I - Electrical connection	400 V, 3N, 50/60

Elco 700HP
Freestanding Electric Fryers

178726

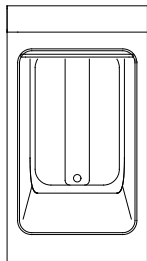
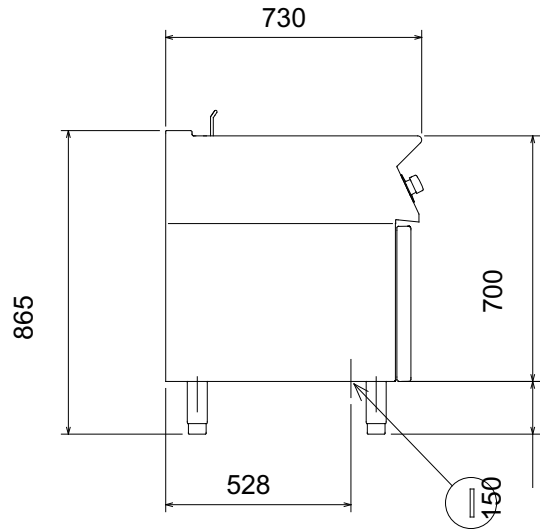
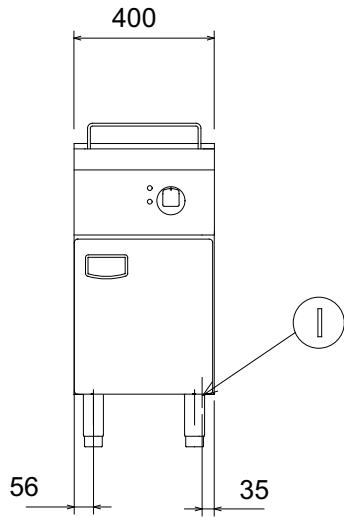

597842200

LEGEND

I - Electrical connection

QFRE455
178726

400 V, 3N, 50/60

CGED010

2008-12-23

Subject to change without notice

Elco 700HP
Freestanding Electric Fryers

178727

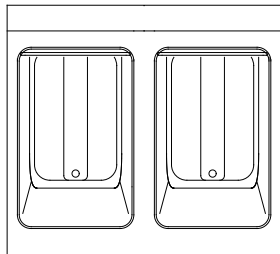
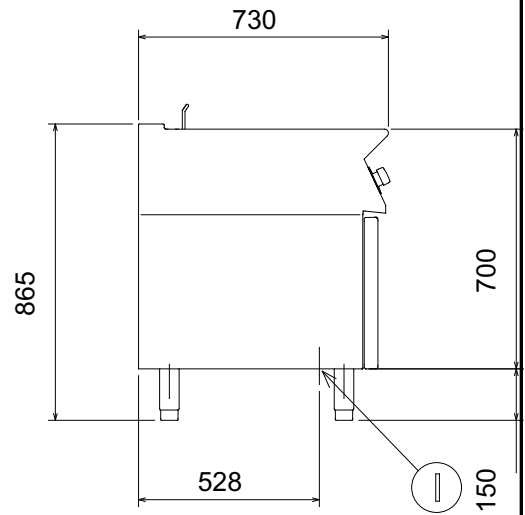
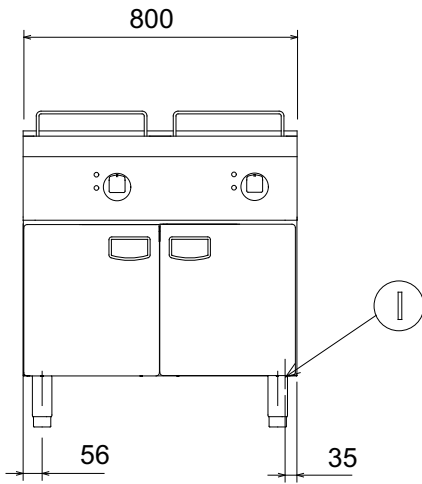

597842300

CGED010

2008-12-23

Subject to change without notice

LEGEND I - Electrical connection	QFRE805 178727
	400 V, 3N, 50/60