

Electrolux Convection Ovens

Conv. oven 10 GN 1/1, Cross-wise

The Electrolux Convection oven range is designed to guarantee high performance and total cooking uniformity while reducing energy consumption. Coupled with its ease of use and robustness of materials used in manufacture, this gives a range second to none. With a choice of 22 different ovens available, and an extensive range of accessories, any installation can be tailored to meet the needs of today's professional caterer.



260701 with base

EASY TO INSTALL

- External access door for electrical connections.
- Height adjustable legs.
- All connections made on the left side below the oven.

EASY TO CLEAN

- 304 grade stainless steel exterior, with seamless joints in the oven cavity.
- IPX4 Water protection.
- Racks easily removed without the need for special tools.
- Integrated drain outlet.

EASY TO USE

- Maximum temperature of 300°C.
- Food temperature probe available as accessory.
- Rapid cooling of oven cavity.
- Halogen lighting and "crosswise" pan supports allow clear and unobstructed viewing of cooking products.
- Unique air-flow channel system guarantees perfect distribution of heat throughout the oven cavity.
- 5 Stage humidification control, to ensure perfect pastries and succulent roasts.

EASY TO MAINTAIN

- Access to main components from the front panel.
- Meets the requirements of CE, VDE and DVGW for safety.
- Platinum probe in the oven gives maximum precision and control during cooking.

EASY ON THE ENVIRONMENT

- Double-glazed door on larger models, with heat-treated glass.
- 98% recyclable by weight.
- CFC free packaging.



Electrolux

260701, 260723

260706, 260727

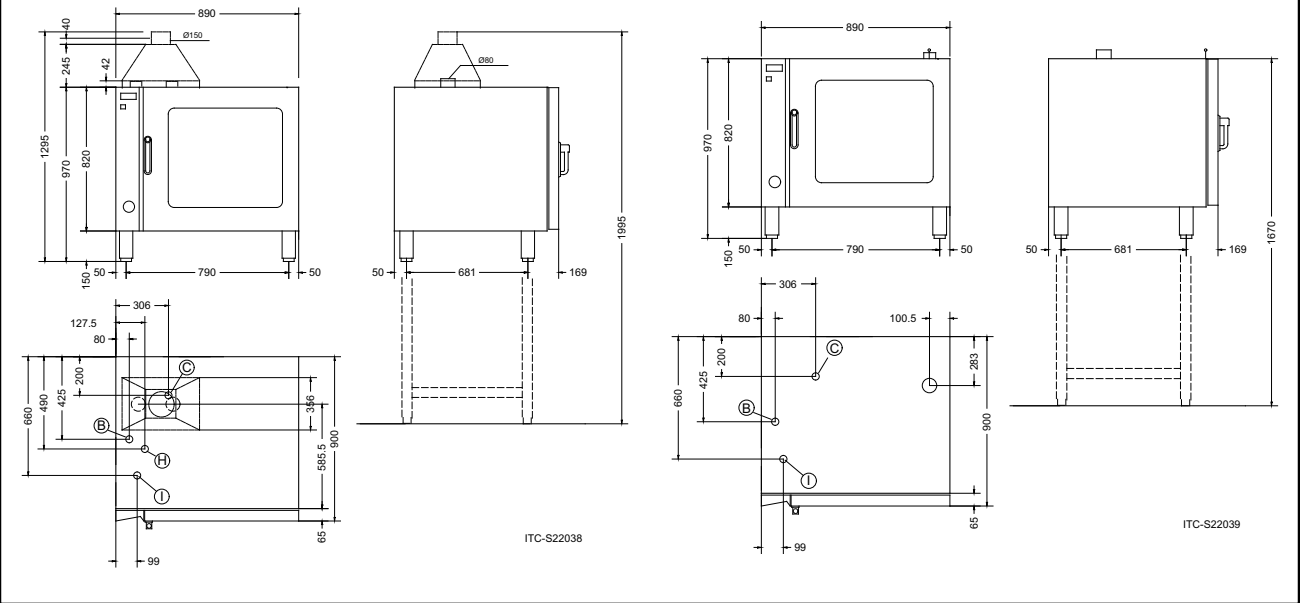

Electrolux Convection Ovens

Conv. oven 10 GN 1/1, Cross-wise

EAA020

2009-02-27

Subject to change without notice

	FCG101 260701	FCG10160 260723	FCE101 260706	FCE10160 260727
LEGEND				
B - Cold water inlet	3/4"	3/4"	3/4"	3/4"
C - Water drain	25mm	25mm	25mm	25mm
H - Gas connection	1/2"	1/2"		
I - Electrical connection	220/230 V, 1N, 50	220/230 V, 1N, 60	400 V, 3N, 50	400 V, 3N, 60
TECHNICAL DATA				
Power supply	Gas	Gas	Electric	Electric
Functional level	Base; Manual	Base; Manual	Base; Manual	Base; Manual
Type of grids	1/1 Gastronom	1/1 Gastronom	1/1 Gastronom	1/1 Gastronom
Shelf capacity	10	10	10	10
Runners pitch - mm	60	60	60	60
Cooking cycles - °C				
air-convection	300	300	300	300
Convection	●	●	●	●
External dimensions - mm				
WxDxH	890, 900, 970	890, 900, 970	890, 900, 970	890, 900, 970
height adjustment	80	80	80	80
Internal dimensions - mm				
width	590	590	590	590
depth	479	479	503	503
height	680	680	680	680
Power - kW				
auxiliary	0.35	0.35	0.3	0.3
electric	0.35	0.35	17.3	17.3
gas	18.5	18.5		
Net weight - kg.	136	136	121.2	121.2
Supply voltage	220/230 V, 1N, 50	220/230 V, 1N, 60	400 V, 3N, 50	400 V, 3N, 60
INCLUDED ACCESSORIES				
60 MM PITCH SIDE HANGERS 10X1/1 ELE.OVEN	1	1	1	1
ACCESSORIES				
1 GRID GN1/1 FOR 8 WHOLE CHICKENS(1.2KG)	922266	922266	922266	922266
1/1GN DRAIN PAN GUIDE KIT	921713	921713	921713	921713
2 GRIDS GN 1/1 FOR CHICKENS (8 PER GRID)	922036	922036	922036	922036
60 MM PITCH SIDE HANGERS 10X1/1 ELE.OVEN			922121	
60 MM PITCH SIDE HANGERS 10X1/1 GAS OVEN	922122	922122		
80 MM PITCH SIDE HANGERS 10X1/1 ELE.OVEN			922115	922115
80 MM PITCH SIDE HANGERS 10X1/1 GAS OVEN	922116	922116		
AUTOMATIC WATER SOFTENER FOR OVENS	921305	921305	921305	921305
BASE FOR 10X1/1GN OVEN ON CASTORS	922114		922114	
BASE FOR OVEN 10X1/1	922102		922102	
CUPBOARD STAND 10X1/1 CONVECTION STEAMER	922118	922118	922118	922118
EXTERNAL SIDE SPRAY UNIT	922171	922171	922171	922171
FAT FILTER FOR GAS OVENS 10&20X1/1-2/1	921700	921700		
FAT FILTER FOR OVENS 10X1/1-2/1			922178	922178
FEET FOR OVENS 10X1/1-2/1	922127	922127	922127	922127
FLUE CONDENSER FOR GAS OVENS 10X1/1-2/1	921701	921701		
FRYING GRIDDLE GN 1/1 FOR OVENS	922215	922215	922215	922215
HOTCUPBOARD STAND 10X1/1 CONVECT.STEAMER	922124	922124	922124	922124
KIT TO CONVERT TO 10X1/1 SLIDE-IN RACK			922201	
PAIR OF 1/1 GN AISI 304 S/S GRIDS	921101	921101	921101	921101
PAIR OF 1/2 GN PAN SUPPORT SHELVES	921106	921106	921106	921106
PROBE FOR OVENS 6-10X1/1	921702	921702	921702	921702
RESIN SANITIZER FOR WATER SOFTENER	921306	921306	921306	921306
RETRACTABLE HOSE REEL SPRAY UNIT	922170		922170	
SHELF GUIDES FOR 10X1/1-OVEN BASE	922106		922106	
THERMAL JACKET FOR SLIDE-IN RACK 10X1/1	922150		922150	
TROLLEY FOR 10XGN1/1 ROLL IN RACK	922130	922130	922130	922130
WATER FILTER FOR OVENS 0.8 L/MIN.	922186	922186	922186	922186